



EXCAVATOR 200 AMPHIBIOUS



Certificate No. JKT6006782 •
JKT6009716/A • JKT6009716/B



PT. PINDAD (PERSERO)

JL. JEND. GATOT SUBROTO NO. 517

BANDUNG 40284 - INDONESIA

TLP. (+62)-22 7312073

FAX. (+62) 22 7301222

E-mail. industrial@pindad.com

bizdev@pindad.com

www.pindad.com



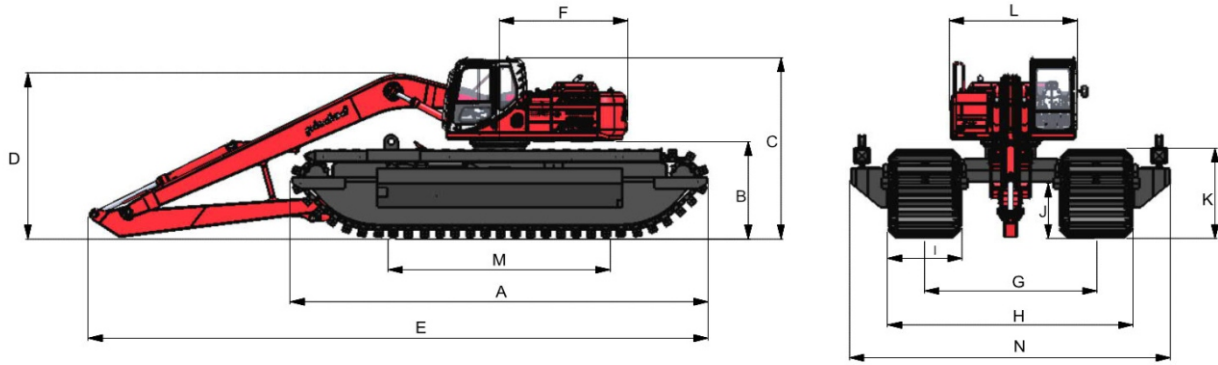

All Dimensions are Approximate

SPECIFICATIONS	
Operating Weight	30000 Kg
Travel Motor Amphibi	2 Motor
Track Link	3 Chain
Engine Type	Inter - Cooled Turbo
Engine Model	DEUTZ BF06M2012C
Power	170 HP / 2000 rpm
Max. Torque	705 Nm / 1500 rpm
Displacement	6.057 L
Number of Cylinders	6
Main Pumps Hydraulic Type	Two Variable Displacement Pumps + 1 Gear Pump
Main Pumps Hydraulic	Parker
Max. Flow	2 x 224.7 L / min
Working Pressure	37.2 Mpa
Swing Motor	Parker
Swing Speed	11 rpm
Fuel Tank Capacity	440 L
Hydraulic Tank Capacity	230 L

DIMENSIONS		STANDARD (mm)
A.	Max. Track Length	9650
B.	Ground Clearance Platform	2270
C.	Overall Cab Height	4133
D.	Height of Boom	3721
E.	Overall Length	13897
F.	Rear Upper Structure Length	2849
G.	Track Gauge	2850 / 4330
H.	Track Width	4470 / 5950
I.	Pontoon Width	1620
J.	Min. Ground Clearance	1300
K.	Track Height	2030
L.	Upper Structure Overall Width	2795
M.	Track Length on Ground	4150
N.	Overall Width	4800/6280

Reach Excavator Working Range Long Boom

WORKING RANGE	REACH
R. Max. Cutting Height	13679 mm
S. Max. Loading Height	11734 mm
T. Recommended Out Reach	15233 mm
U1. Max. Digging Depth from Front	10749 mm
U2. Max. Digging Depth from Side	8234 mm
Bucket Capacity (m ³)	0.5 m ³

