

pindad

MINI EXCAVATOR

EXCAVA 50 STANDARD



PT. PINDAD (Persero)

JL. Jend. Gatot Subroto No. 517

Bandung 40284 - Indonesia

Phone (+62) 22 7312073 – Ext. : 2216 ; Fax. (+62) 22 7301222

e-mail : industrial@pindad.com ; bizdev@pindad.com

www.pindad.com

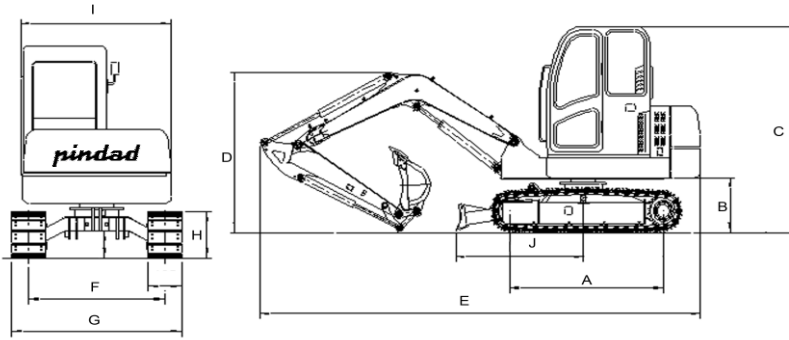

All Dimensions are Approximate

| SPECIFICATIONS | |
|-----------------------------|--------------------------------|
| Operating Weight | 5000 Kg |
| Engine Model | YANMAR 4TNV88 |
| Power | 35 kW/2300 rpm |
| Max. Torque | 165 Nm/1650 rpm |
| Main Pumps Hydraulic Type | Two Variable Pumps + Gear Pump |
| Ground pressure | 31 kPa |
| Implement circuit | 24,5 Mpa |
| Traveling Speed | 3,5 km/h |
| Swing Speed | 11 rpm |
| Max traction force | 45 kN |
| Fuel Tank Capacity | 75 L |
| Hydraulic Tank Capacity | 85 L |
| Engine Oil Capacity | 7,5 L |
| Radiator Coolant Capacity | 3 L |
| Overall Dimension | 5860×1850×2550 mm |
| Dozer blade(Width × Height) | 1870×310 mm |

| DIMENSIONS | | (mm) |
|------------|---------------------------|------|
| A. | Length of track on ground | 1915 |
| B. | Ground Clearance Platform | 680 |
| C. | Overall Cab Height | 2550 |
| D. | Height of Boom | 2090 |
| E. | Overall Length | 5860 |
| F. | Track Gauge | 1450 |
| G. | Track Width | 1850 |
| H. | Track Height | 560 |
| I. | Cabin Width | 1750 |
| J. | Blade Distance | 1620 |

Reach Excavator Working Range Long Boom

| WORKING RANGE | REACH |
|---|---------------------|
| R. Max. Cutting Height | 5620 mm |
| S. Max. Loading Height | 3980 mm |
| T. Recommended Out Reach | 6030 mm |
| U1. Max. Digging Depth from Front | 3750 mm |
| U2. Max. Digging Depth from Side | 3000 mm |
| D1 Blade bottom highest position above ground | 340 mm |
| D2 Blade bottom lowest position above ground | 480 mm |
| Bucket Capacity (m ³) | 0,18 m ³ |

