

class



customers

- PT. Adiluhung Saranasegara Indonesia
- PT. Bayu Bahari Sentosa
- PT. Benua Raya
- PT. Bintang Timur Samudera
- PT. Daya Radar Utama
- PT. Dok dan Perkapalan Surabaya (Persero)
- PT. Dok Perkapalan Kodja Bahari (Persero)
- PT. Dumas Shipyard
- PT. Global Trading
- PT. Industri Kapal Indonesia (Persero)
- PT. Onasis Indonesia
- PT. Pal Indonesia (Persero)
- PT. Pelayaran Nasional Meladya Makmur
- PT. Sanur Marindo Shipyard
- PT. Sarana Samudera Pacific
- PT. Pahala Harapan
- PT. Tesco Indomaritim
- PT. Trisila Laut
- Zhang Hong Private Limited Singapore



*Pin*MARINE



PT. PINDAD (Persero)

Jalan Jend. Gatot Subroto 517 Bandung 40284, Indonesia
Phone: (62-22) 7301574, 7312073 (Hunting) Ext. 2428
Fax.: (62-22) 7304293
Homepage: <http://www.pindad.com>
Email: marine@pindad.com

catalog of products

winches

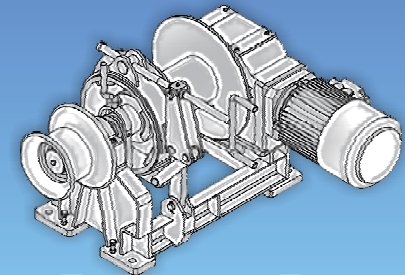

winches

*Pin*MARINE



STRUCTURAL FEATURES

Pulls: 10 - 1000 KN

Chain Diameters: 12.5 mm - 127 mm stud link chains and roller chain stoppers (bigger chain diameters on request)

Chain Diameters: 12.5 mm - 127 mm stud link chains and roller chain stoppers (bigger chain diameters on request)

Single or double drum in waterfall design or liner design

Undivided or split-type drums

Design with fully or partially enclosed gear

With or without remote control for mooring winch part

With or without remotely controlled letting-go the anchor, with automatic speed limitation

With or without remote control from ship sides or wheelhouse

With pole-changing motor or frequency controlled for stepless speed control

Tailor-made to customer requirement

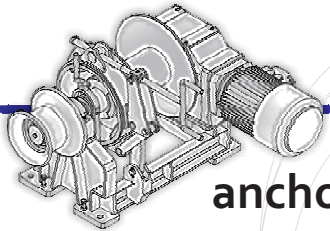

electric anchor winch

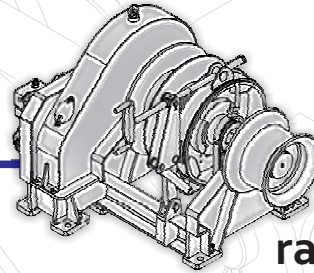

hydraulic ramp winch

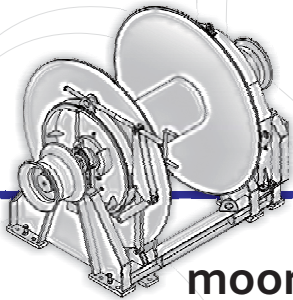

hydraulic mooring winch

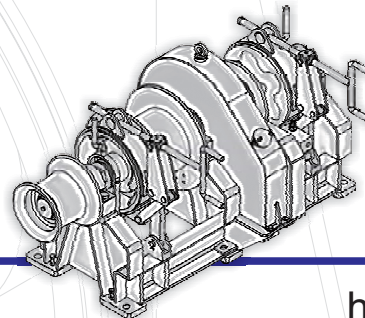

hydraulic combination windlass

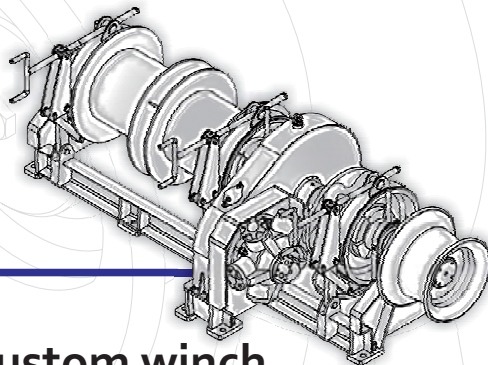

custom winch

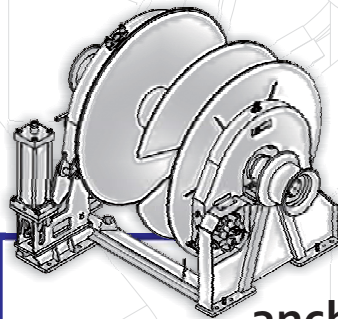

hydraulic anchor winch